

Dynamic Stander

K110, K130, K150 & K170 Product Manual



CE

 rifton®

Contents

Warnings and important information	3
Recommended use	4
Check your order	4
User and item dimensions	5
Basic item	6
Accessories	
Sandals & wedges	7
Additional seat pad	9
Arm prompt set with mounting bracket	10
Hand loop set with mounting bracket	11
Communication tray mounting bracket	12
Operation	13
Cleaning	14
Maintenance	14
Materials	15
User modifications	15

Key for EU users

Use this key to determine which sections of this product manual apply to you.

 **Technical Users** For professionals who order and set up Rifton products.

 **Home Users** For care-givers who use Rifton products on a regular basis.

 **Maintenance Personnel** For anyone who is responsible for service or re-ordering of Rifton products and parts.

WARNINGS

- Thoroughly read and understand the information in this product manual before attempting to use this product. If the procedures and instructions in this manual are not followed, serious injury could occur.
- A qualified professional must assess the appropriateness and safety of all equipment for each user.
- Correct use of this product requires the prior approval and ongoing guidance of a qualified therapist or physician.
- This product is intended for use by children of immature judgment. Adult supervision is required at all times.
- Do not use this product on rough and uneven terrain, around swimming pools, or near stairways.
- All mobility equipment may become unstable when used improperly.
- Straps and supports are provided for the safety of the user and must be carefully adjusted for comfort and security. The use of straps and supports must be supervised at all times.
- Restraints – Using straps, trays or supports to restrict a child’s movement is considered behavioral restraint, which may raise ethical and legal issues for your facility. Rifton Equipment is not intended for this use.

IMPORTANT

- Please save this product manual. Additional copies are available at www.rifton.com
- Please refer to the Rifton product catalog for our full warranty, or visit www.rifton.com

Recommended use

The Dynamic Stander is designed to help a child stand. The straps, seat pad and contoured body support allow full to no weight-bearing by a user who has no active use of trunk and leg muscles.

The wide-standing platform helps the user to spread his or her legs for hip development and can accommodate leg braces. To facilitate placing the child in the stander, the platform has no obstructions.

The Dynamic Stander is appropriate for your **MOVE Curriculum**. Available from MOVE International, the curriculum explains the MOVE program and use of specially designed MOVE equipment.

Check your order

Your Dynamic Stander comes fully assembled.

If your shipment is incomplete or in any way damaged on arrival, please call Customer Service, 800.571.8198.

User and item dimensions

User dimensions – Inches (cm)	K110 mini	K130 small	K150 medium	K170 large
Height	25-32 (64-81)	30-40 (76-102)	37-52 (94-132)	48-65 (122-165)



Key user dimension: height

Select the appropriate Dynamic Stander by the user's overall height.
Choose the model that allows for growth.

Important: User's weight must not exceed the maximum working load.

Item dimensions – inches (cm)	K110 mini	K130 small	K150 medium	K170 large
Overall length and width	25 x 25½ (64 x 65)	25 x 25½ (64 x 65)	32 x 29 (81 x 74)	39 x 33½ (99 x 85)
Overall height	22½-28 (57-71)	23½-30 (60-76)	30-39 (76-99)	37½-49 (95-124)
Width without big wheels	21 (53)	21 (53)	25 (64)	28½ (72)
Wheel diameter	20 (51)	20 (51)	27 (69)	35 (89)
Width of body support	7-10 (18-25)	7-10 (18-25)	9-12 (23-30)	10-14 (25-36)
Height of body support	16½-22 (42-56)	22-29 (56-74)	29-38 (74-97)	36-48 (91-122)
Item weight – lbs (kg)	28 (13)	30 (14)	40 (18)	65 (29)
Max. working load – lbs (kg)	50 (23)	50 (23)	120 (54)	175 (79)

Basic item

Adjustments

See Figure 6a and 6b.

1. Use knobs (A) to adjust body support up and down. Before the child is placed in the stander, always adjust body support height and tighten both knobs (A).
2. Use four knobs (B) to adjust width of body support.
3. Top strap (C) can be adjusted and positioned at center of back underneath the arms, or crossed in front of the body support. It can also pass behind the head to be used as a neck support.
4. The seat pad (D) can be adjusted up and down and angled in a variety of ways. Four separate straps (E) and multiple snap hook positions (F) allow for individualized positioning. By adjusting the position and angle of the seat pad, the child can be firmly supported in an upright standing position or in a flexed stance to allow for contractures of hips and knees. For more support a second seat pad can be placed in the middle of the back.
5. Knee straps (G) secure the knees in a standing or partially standing position. If a child needs abduction, two additional straps can be ordered. For a small child, use the top slots in the body support for the knee straps. For a larger child, use both bottom slots.
6. Optional 32" wheels can be removed using a simple push button. Rolling casters allow for convenient interaction between the child and his or her environment.

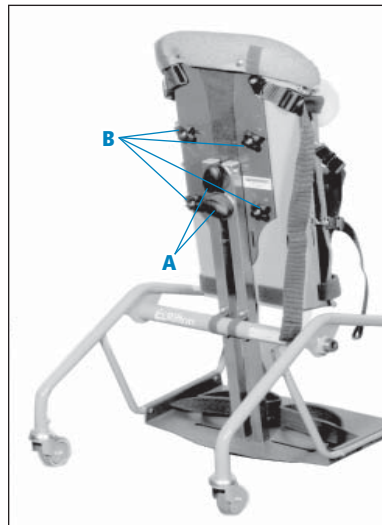

Figure 6a



Figure 6b

Accessories

Sandals & wedges

Recommended use

Sandals with wedges are designed for use with the Dynamic Stander to position and hold feet firmly on a wide platform to encourage standing.

The K114 pair of sandals with wedges are designed for the K110 mini and K130 small Dynamic Stander.

The K154 pair of sandals with wedges are designed for the K150 medium Dynamic Stander.

The K174 pair of sandals with wedges are designed for the K170 large Dynamic Stander.

Assembly

1. Loosen both knobs (D) on the right sandal. It has heel straps to the rear and adjustment knobs on the instep (see Diagram C).
2. Position sandal on platform and insert first bolt head into key slot (see Diagram A).
3. Rotate sandal to position and insert other bolt head into key slot (see Diagram B).
4. Rotate and/or slide sandal to desired position. Pull upwards on knobs while turning to tighten.
5. Repeat steps 1–3 for left sandal.

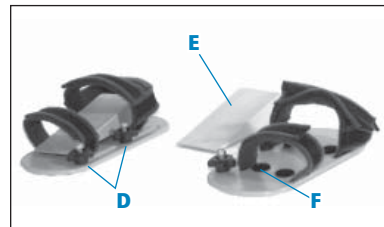

Figure 7a. Pair of sandals with wedges

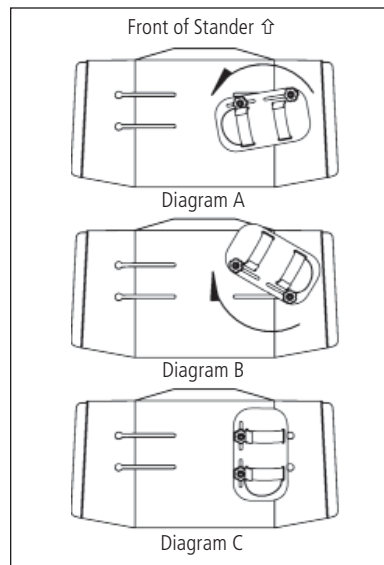

Figure 7b

Adjustments

1. Use knobs (D) to adjust sandal forward and back, side to side, and to desired foot angle on platform. Dual knob adjustment provides versatile foot positioning (see Figure 7a).
2. Wedges (E) can be used to elevate the toe or heel according to the child's needs. Hook on the bottom of wooden wedge adheres to loop dots on sandal, (F). If one of the child's legs is shorter two wedges can be combined and placed underneath the foot to raise it. To combine two wedges, the extra loop dots provided should be placed on face (E).

Additional seat pads

K135 (small), K155 (large) 🧑 🏠 🦽

Recommended use

The K135 small and K155 large additional seat pads are designed for the K150, 25" and K170, 32" Dynamic Stander. Seat pads provide support for full weight-bearing and can be adjusted to accommodate all positions from sitting to standing.

Assembly

1. Snap four snap-hooks (A) into metal loops (B) on body support (see Figure 9a).

Adjustments

1. Adjust strap length by pulling or pushing end of strap through buckle (C).
2. It is recommended that snap-hooks (A) are used when placing a child in the stander. When removing the child from the stander, release buckles (C).
3. To position seat pad at an angle, connect buckle in back of seat pad (D) to center strap on body support, and adjust straps.

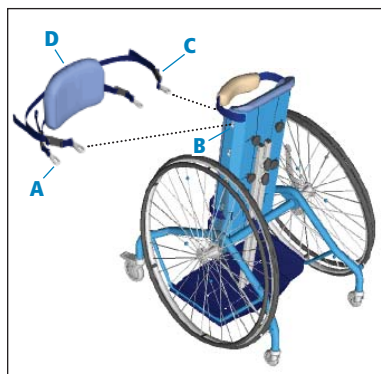

Figure 9a

Arm prompt set with mounting bracket 🧑🏠🙋

Recommended use

The mounting bracket, tray, arm prompts and hand loops are for use with Dynamic Standers only. The arm prompt set gives additional support for a child with poor head and/or shoulder control. It stimulates the child to raise his/her head. The mounting bracket is needed to attach the arm prompts, hand loops and/or attach communication tray on Rifton Dynamic Standers.

Installation of mounting bracket

Loosen the top two knobs (A) on the body support of the Dynamic Stander. Slide the slotted mounting bracket (B) behind the knobs and tighten them securely. Arm prompts, hand loops and/or the communication tray can now be attached (see Figure 10a).

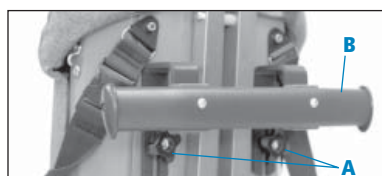

Figure 10a

Arm prompt set

Loosen the clamp knob (C) and pull it down to free the curved metal piece. Slip the clamp over the oval tube of the mounting bracket with the main part of the clamp to the side of the mounting bracket. Close the curved metal piece, pull the knob up, and tighten it securely (see Figure 10b).

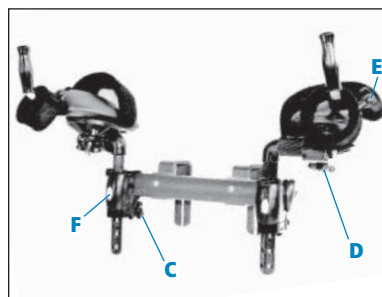

Figure 10b

Adjustments

Use knob (D) to adjust arm prompt sideways, forward or backwards, for elbow rotation, and to angle up or down.

Use knob (E) to rotate the handhold or adjust it in and out.

To position arm prompt further forward press the clamp button and slide the prompt out. Next, loosen knob (C) and remove the clamp from the mounting bracket. Turn the clamp around and remount it with its knob to the inside. Slide the arm prompt back into the clamp.

NOTE: To benefit from the full range of adjustment of the arm prompts, removing the large wheels while the prompts are in use is recommended.

Press button (F) to adjust the height of hand loop. Press button (F) and slide post up or down to desired position. Release button to engage into desired position.

Hand loop set with mounting bracket 🧑🏠🦽

Recommended use

The mounting bracket, tray, arm prompts and hand loops are for use with Dynamic Standers only. The arm prompt set gives additional support for a child with poor head and/or shoulder control. It stimulates the child to raise his/her head. The mounting bracket is needed to attach the arm prompts and/or attach communication tray on Rifton Dynamic Standers.

Installation of mounting bracket

Loosen the top two knobs (A) on the body support of the Dynamic Stander. Slide the slotted mounting bracket (B) behind the knobs and tighten them securely. Arm prompts and/or the communication tray and/or hand loops can now be attached (see Figure 10a).

Hand loop set

Loosen the clamp knob (C) and pull it down to free the curved metal piece. Slip the clamp over the oval tube of the mounting bracket with the main part of the clamp to the inside of the mounting bracket. Close the curved metal piece, pull the knob up, and tighten it securely (see Figure 11a).

Adjustments

Loosen knob (C) to completely remove hand loop from mounting bracket.

Loosen knob (D) to tilt the hand loop to desired position. Tighten knob secure.

Press button (F) to adjust the height of hand loop. Press button (F) and slide post up or down to desired position. Release button to engage into desired position.

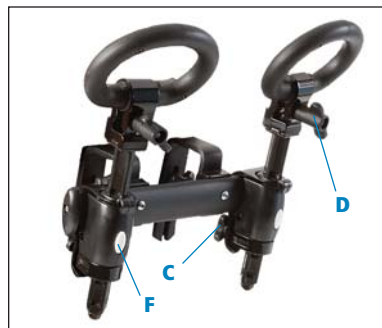

Figure 11a



Figure 11b

Communication tray with mounting bracket

Recommended use

The communication tray provides a surface for personal communication devices and for other activities. Communication sheets can be placed under the false bottom and electronic devices can be secured to the tray. The tray can easily be removed when not needed.

Installation of communication tray

The same mounting bracket used for hand loops or arm prompts can also accommodate a tray for manipulative activities and communication devices (see mounting bracket installation instructions on Page 10).

Loosen the clamp knob (C) and pull it down to free the curved metal piece. Slip the clamp over the oval tube of the mounting bracket with the main part of the clamp to the side of the mounting bracket. Close the curved metal piece, pull the knob up, and tighten it securely (see Figure 10b).

Adjustments

To adjust the tray (see Figures 12a and 12b)

1. Loosen knob (A) to change the tilt angle of tray or to rotate the tray from side to side.
2. To adjust height of the tray, press button (B), slide post to the desired position, and release button (B).
3. Loosen knob (C) to completely remove tray.
4. The tray insert can be removed by pressing upward through the holes. Reinstall insert by placing tabs in slots at the bottom of tray. Then press down on front top edge of insert until it snaps in place.

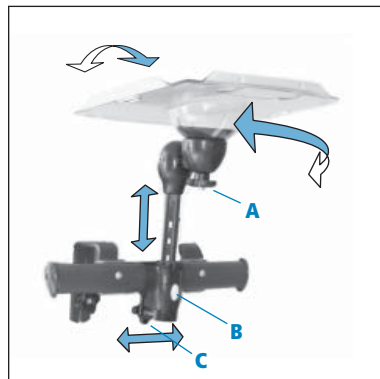

Figure 12a

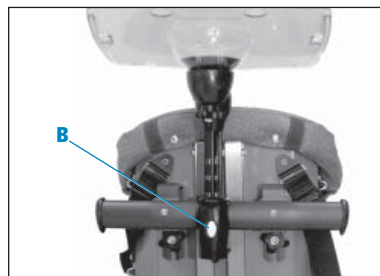

Figure 12b

WARNING

This accessory is intended for use on the Rifton Dynamic Stander only.

CAUTION

The tray is meant to support activities compatible with mobility. It is not designed to be used as a restraint or for body support.

Operation

To safely place a child in the Dynamic Stander, immobilize the unit by applying the wheel locks.

Release snap hooks or buckles on one side of seat pad and center strap of seat pad, allowing seat pad to swing out of the way.

Release one side of top strap and swing it out of the way.

Carefully place the child into the stander from the back.

The seat pad should be placed under the child's buttocks. If the child is non-weight-bearing, position it at an angle appropriate to bear the child's weight. If the child is weight-bearing, the pad should be positioned vertically.

The top strap, with fleece in back, should be placed under the child's arms and fastened behind the child's back.

After placing the child in the unit, review the following checklist:

- Is the bottom of the body support below the knees?
- Is the top of the body support about nipple level or lower?
- Are the feet placed under the hips and as far forward on the platform as possible without causing discomfort?
- Is the body properly aligned?
- Is the body support adjusted to the proper width?
- Are all the straps fastened and snug?
- Is the child free of discomfort?

When removing the child from the stander, ensure that the child is sufficiently supported as straps are being released. Begin by releasing restraints from the feet and work upwards.

Cleaning 🧑🏠 🧽

Clean metal parts with a cloth, water and a mild detergent or mild disinfectant and rinse well. Vinyl pads can be cleaned the same way, or use a commercial cleaning agent suitable for imitation leather. The fleece sleeve can be removed for laundering.

Maintenance 🧑🔧

Periodically inspect for cracks, breaks, loose parts, missing parts, and/or malfunctions. Remove the product from service when any condition develops that might make operation unsafe.

Inspect straps and padding twice a year for damage, and replace if necessary.

Twice a year, perform the following maintenance:

- Apply a drop of oil to the caster bearings and wheel axle.
- Inspect all nuts. Tighten if necessary.
- Inspect strap stitching and replace if they become frayed.

Materials 🧑

- Steel hardware items (nuts, bolts, screws, etc) are typically zinc or nickel plated, or stainless steel.
- Upholstery items (pads, support blocks, padded prompts, etc) are typically fire-retardant polyurethane foam with a fire-retardant cover made from expanded vinyl.
- Frames are typically steel or aluminum tubing, welded together, and coated with a baked-on paint finish. Some frame components may also be stainless steel.
- Tires are tubeless, filled with polyurethane foam, and do not require inflation.
- Straps are typically made of polypropylene or nylon webbing.
- Wooden components are typically birch plywood, solid maple, or laminated hardwood veneers, finished with a clear polyurethane lacquer.
- Tabletops are typically high-pressure laminate (Formica).
- Plastic components are typically injection molded from a variety of industrial resins.

All materials are latex, lead and phthalates free.

User modifications 🧑🏠🧑

We recognize that some clients may benefit from modifications made in the field. However, we cannot be responsible for customer modifications made to our products without our explicit supervision, testing or evaluation.

Rifton Contact Info



Online

www.Rifton.com
Sales@Rifton.com



Phone

800.571.8198
9-5 EST



Mail

Rifton Equipment
PO Box 260
Rifton NY 12471-0260



Fax

800.865.4674

To order replacement parts

1. Locate the serial number of the product on the small white label.
2. Have this number available when you call **800.571.8198** for your customer service representative.

Use only replacement parts supplied by Rifton Equipment.